

Data Acquisition Form for FMS Belt Scales



To suggest a specific offer, we need some information about your application.
Please complete the data sheet as much as possible and return it to us. Thank you.

**Please fill in and send
to the below address.**

Name : _____	Phone : _____
Company : _____	Project : _____
Bulk material : _____	
Flow rate (Q) max: _____ min: _____	[t/h]
Belt speed (v) : _____	[m/s]
Distance between the supporting roller stations (a) : _____	[mm]
Weight of belt per m ² (m _G) : _____	[kg]
or kind of belt (type, design) : _____	
Width of belt (b) : _____	[mm]
Trough angle (0° for flat belt) (λ) : _____	[°]
Width of center part (l ₃) : _____	[mm]
Inclination of the belt (φ) : _____	[°]
Admissible measuring error : ± _____	[%]
Length of cable from roller to electronic unit : _____	[m]

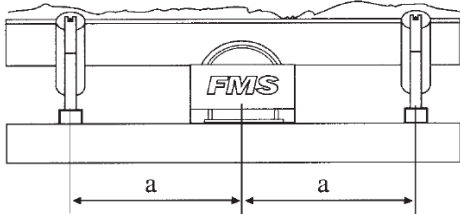
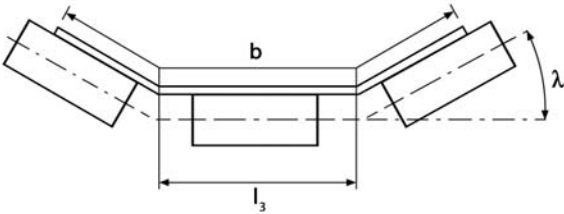
Required features of the electronic unit

Supply voltage: <input type="checkbox"/> 110-230 VAC <input type="checkbox"/> 24 VDC Housing version: <input type="checkbox"/> wall mounted (W) <input type="checkbox"/> control panel mounted (S) <input type="checkbox"/> steel cabinet (K) <input type="checkbox"/> 19" OEM	Options: <input type="checkbox"/> Printer <input type="checkbox"/> Limit switches <input type="checkbox"/> Charge preselection (additional digital input and output) <input type="checkbox"/> Profibus <input type="checkbox"/> Analogue display <input type="checkbox"/> Remote counter
---	---

Remarks / Drawing:

World Headquarters:

FMS
Force Measuring Systems AG
 Aspstrasse 6
 8154 Oberglatt (Switzerland)
 Phone + 41 44 852 80 80
 Fax + 41 44 850 60 06
 info@fms-technology.com

FMS USA, Inc.
 2155 Stonington Avenue,
 Suite 119
 Hoffman Estates, IL 60169
 Phone 847 392 7872
 Fax 847 392 7873
 fmsusa@fms-technology.com

FMS UK
 Highfield, Atch Lench Road
 Church Lench
 Evesham WR 11 4UG
 Phone 1386 871023
 Fax 1386 871021
 fmsuk@fms-technology.com

FMS Italy
 Via Baranzate 67,
 I-20026 Novate Milanese
 Phone 02 39487035
 Fax 02 39487035
 fmsit@fms-technology.com

www.fms-technology.com